



P817-PG-24X24
24 [610] Wide Perforated Grate

Dimensional Data (inches and [mm]) are Subject to Manufacturing Tolerances and Change Without Notice

[Back to Index](#)

Please Check	Item No.	Part Number	Item I.D.
✓	8	61029	P817-PG-24X24

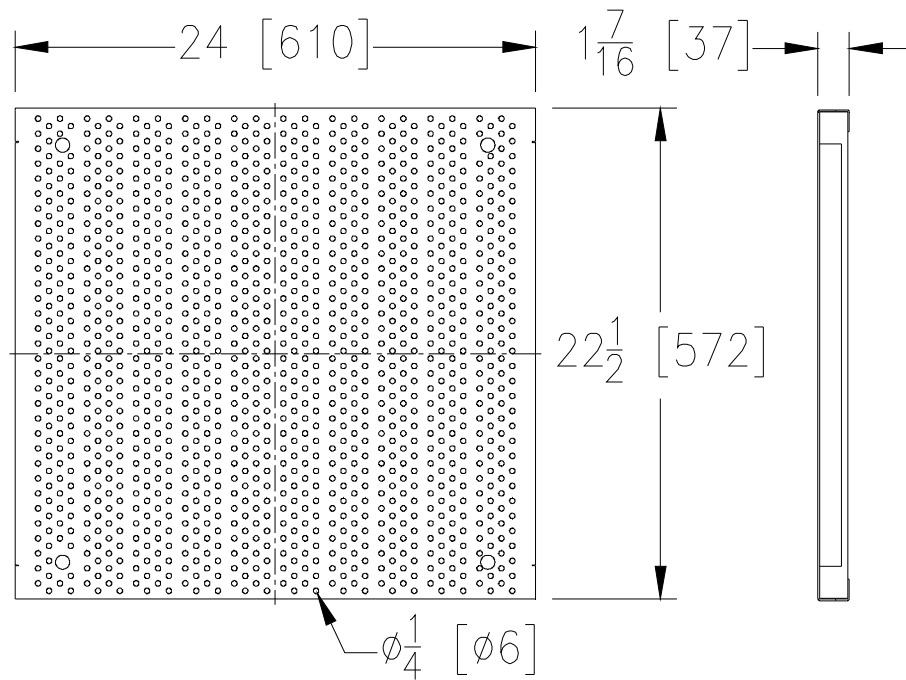

PG GRATE ENGINEERING SPECIFICATION: The Zurn P817-PG-24X24 Perforated Grate, Galvanized Steel, 24 inches wide by 22-1/2 inches long, weighing 46.7 lbs. The grate has an open area of 62.5 square inches, DIN Rating of A, ANSI Rating of Light-Duty, ADA Compliant.

PG - Perforated Grate	
Material:	Galvanized Steel
DIN Rating:	Class A
Weight:	46.7 lbs.
Open Area:	62.5 in ²
ANSI Rating:	Light-Duty
Application:	Decorative Heel-Proof
Slot Width/Hole Size:	1/4
ADA:	Yes
H-20:	No
FAA:	No